

Linear Actuator

LAC Series

20. HIWIN LAC Series (1)

LAC1

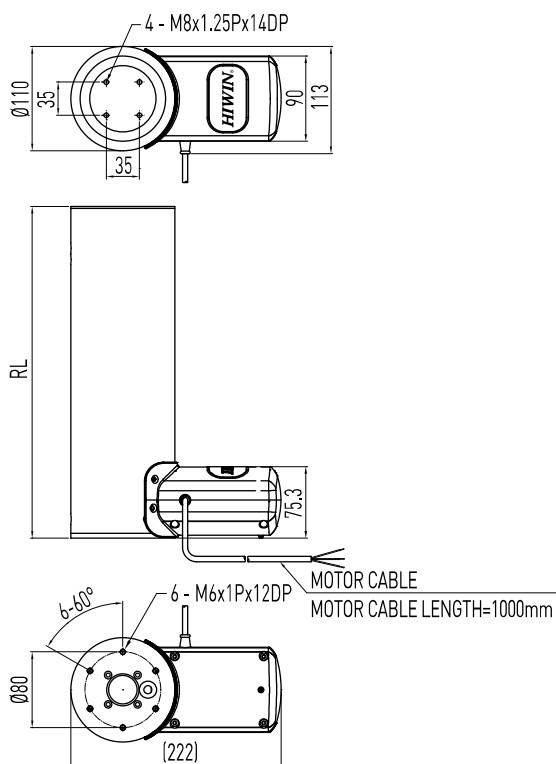

- $RL = 150 + S/2$
 RL: Retracted length
 S: Stroke length

Table 20.1 Specifications

Screw type	ACME
Weight*	5.6kg
Protection	IP54
Compatible controller	Compatible with all controllers (*Notice the type of connector: Audio/DIN 4pin)
Working temp.	+5°C~40°C

* Stroke length 400mm

Option:

- (1) Hall sensor
- (2) Potentiometer
- (3) Plug : DIN 4PIN plug / Stereo plug / Mono plug

Table 20.2 LAC1 Specifications

Model	Thrust max. (N)	Pulling max. (N)	Holding max. (N)	Speed (mm / s) Load = Max. / Load = 0	Standard stroke (mm) : S	Duty cycle %	Current max. (A) 24VDC	Potentiometer Resolution (ohm/mm)	Hall Sensor Resolution (mm/pulse)
LAC1-1	2000	500	2000	8 / 12	300 400 500	10	5	6.67	1.0

* Min. input power = Voltage x Current max.

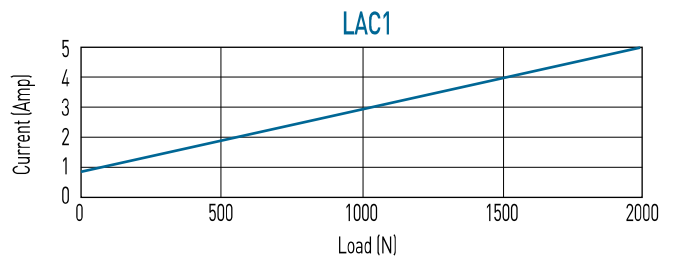
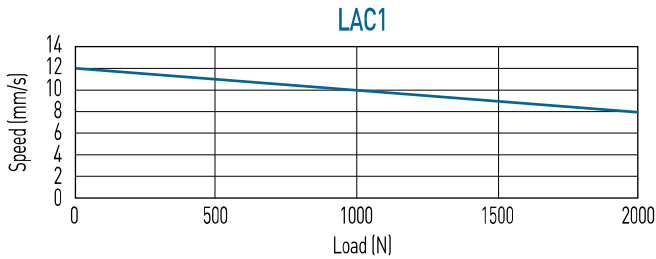

**Note: The test results are obtained by using the 24VDC power supply.

Table 20.3 LAC1(24Q) Specifications

Model	Thrust max. (N)	Pulling max. (N)	Holding max. (N)	Speed (mm / s) Load = Max. / Load = 0	Standard stroke (mm) : S	Duty cycle %	Current max. (A) 24VDC	Potentiometer Resolution (ohm/mm)	Hall Sensor Resolution (mm/pulse)
LAC1-1	2000	500	2000	13/16	300 400 500	10	8	6.67	1.0

* Min. input power = Voltage x Current max.

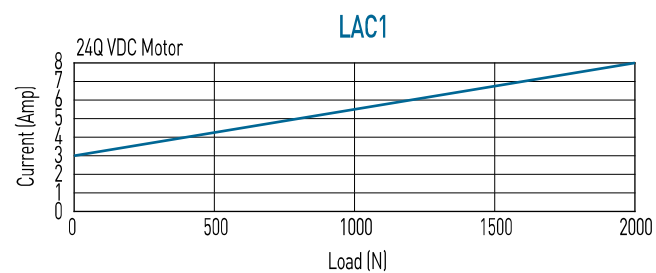
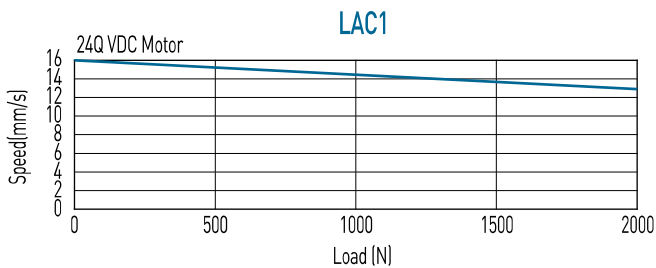

LAC1 Bending moment illustration

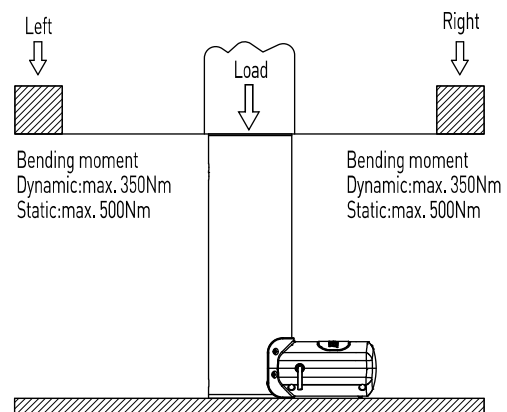

Ordering Information

LAC1 - 1 - 1 - 400 - 24 G E					
Model number	1: Basic model complete with internal limit switches	Stroke length	Voltage	Color G : Gray	Special models according to the customer's requirement (Ignore this part of the serial number if not available)