

Motor Bracket MBB (Hidden Type)

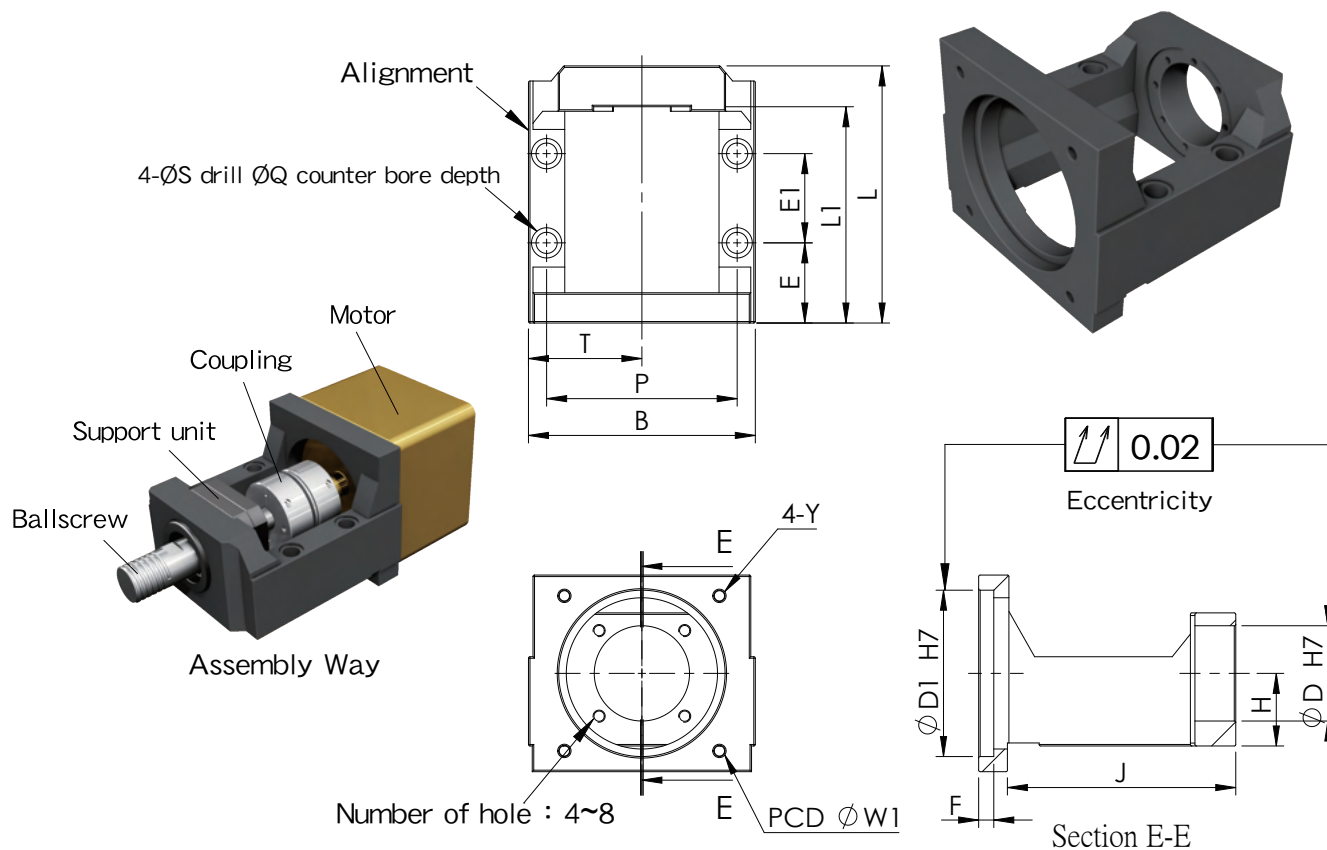

Unit : mm

Model No.	Dimensions of Motor Bracket															Support unit		Suggest Coupling			
	D1	W1	Y	D	L	L1	H ±0.02	B	P	T	S	Q	E	E1	F	J	Weight (Kgs)		Fixed-side	Supported-side	
MBB20L-G				57														FK20B	BF20H	SGL 65C	
MBB20-G	110	145	M8	58	170	143	48	150	126	75	14	20	53	59	10	151	5.61	MBK15DF MBK17DF MBK20DF	BF15+20mm BF17+9mm BF20H		
MBB25L-S		130			168	141							51	59	8	146	5.94	FK25	BF25		SGL 65C SGS 65C
MBB25L-G	110	145	M8	63	170	143	48	150	126	75	14	20	53	70	10	151	5.47				
MBB25L-G-M													55	70	10	151	6.05				
MBB30-H	114.3	200	M12	85	230	189	51	200	170	100	18	26	75	75	Thru hole	201	11.02	WBK25DF WBK25DFD WBK30DF WBK30DFD	SF25 SBK25 BF30 SBK30	SAP-82C SAP-94C	
※ MBB30-I	130	165	M10	85	230	189	51	200	170	100	18	26	75	75	10	201	11.15	WBK25DF WBK25DFD	SF25 SBK25	SAP-82C SAP-94C	
※ MBB30-J	150	185															11.1	WBK30DF WBK30DFD	BF30 SBK30		

※Customized ◦

Note : 1.Can choose B angle bearings when use support unit with FK20/FK25